

Determining the Proper E-Z Flex™ Unit

To help you determine the proper E-Z Flex™ kit for your unit, please refer to the drawings shown below.

If the measurement of the equalizer on your unit falls within these measurements, order kit K71-652-00 tandem or K71-656-00 triple.

For more information please click [here](#).

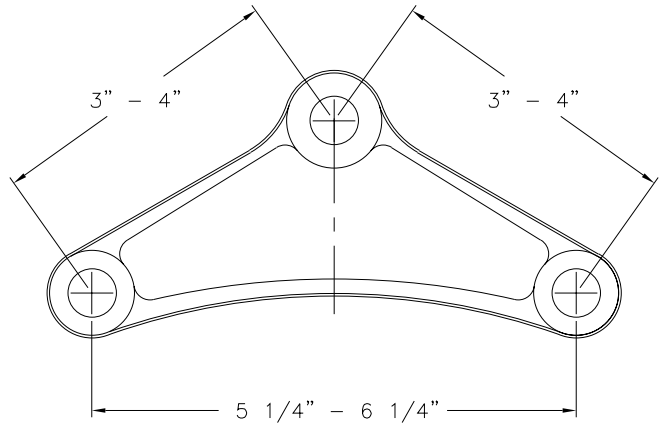

If the measurement of the equalizer on your unit falls within these measurements, order kit K71-653-00 tandem or K71-657-00 triple.

For more information please click [here](#).

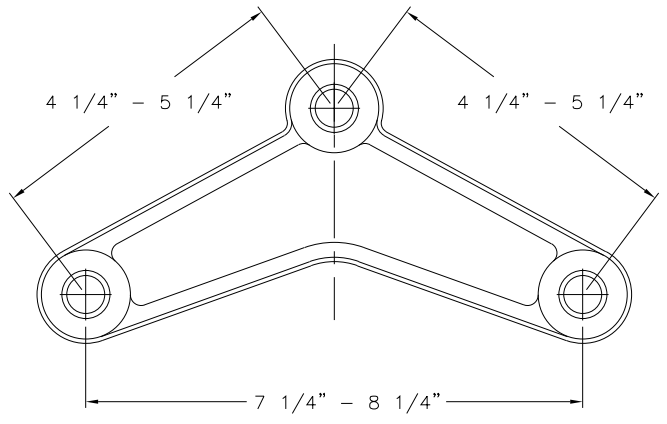

If the measurement of the equalizer on your unit falls within these measurements, then the E-Z Flex™ kit will lower your unit approximately 1.0".

NOTE: You will need to check the bump clearance to insure that when you lower the frame of the unit, you still maintain 1.50" minimum of bump clearance.

What is bump clearance? Bump is the upward displacement of a wheel center relative to the trailer frame (sprung mass). Clearance is the amount of trailer frame to axle clearance necessary to allow the axle to clear or NOT contact the trailer frame.

If everything indicates that you can lower the frame 1.0" and still maintain the required 1.50" of bump clearance, then order kit K71-652-00 tandem or K71-656-00 triple.

For more information please click [here](#).

